

FMA – 6000

INSTALLATION, OPERATION AND MAINTENANCE MANUAL

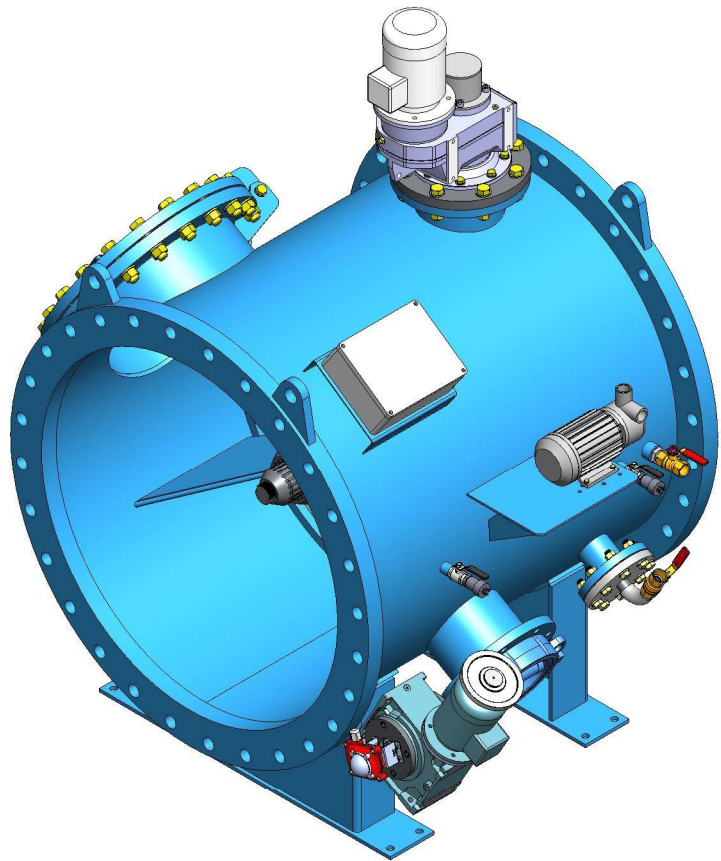

TABLE OF CONTENTS

INTRODUCTION.....	3
SAFETY INSTRUCTIONS.....	4
TECHNICAL SPECIFICATIONS	5
HEAD LOSS CHART.....	10
RECOMMENDED INSTALLATION DIMENSIONS AND DESIGN.....	12
INSTALLATION AND START-UP INSTRUCTIONS.....	12
INSTALLATION DIAGRAM	14
MASTER PANEL PERFORMANCE	14
PRESSURE DIFFERENTIAL REGULATION	24
EXPLOSION DIAGRAM	26
HYDRAULIC LAYOUT	31
ELECTRIC PANEL	32
ELECTRIC LAYOUTS	33
PREVENTIVE MAINTENANCE SCHEDULE.....	38
REFERENCES.....	39

INTRODUCTION

GENERAL

STF filtros congratulates you on the acquisition of the FMA 6000 self backwashing automatic filters.

This filter joins the STF filters wide range for agriculture, water treatment, sewage treatment plants and other industrial use. All the products manufactured by STF-FILTROS are easy to install, use and maintain and no special knowledge is required to operate them.

WARRANTY

The product has a two-year warranty from the moment of acquisition.

- Follow this manual instructions to operate and maintain the filter.
- Mechanical damages or any other damages caused by incorrect use are excluded from warranty.
- The warranty gets also cancelled in case that no original spares are used.

SAFETY INSTRUCTIONS

1. Prior to installation or filter operation, read carefully this manual.
2. Please note, the filters enters into a backflushing mode automatically, without prior warning.
3. Non authorized modifications or changes on the equipment are permitted.
4. Filter installation should be performed so as to avoid direct water splashing on the electrical components.
5. Take correct precautions when raising and placing the equipment so that no damages are produced.
6. Make sure to leave enough clearance so as to enable easy access for future treatments and safe maintenance operations.
7. It is necessary to place a shut-off valve in the collector before the equipment to make the maintenance easier.
8. Make sure that the equipment is operating at a correct working pressure.
9. Disconnect the filter from power supply before maintenance or treatment.
10. Never switch on the equipment without placing all the safety elements.
11. Don't carry out a different maintenance different from the indicated in this manual.
12. Use only original spare pieces.

TECHNICAL SPECIFICATIONS

Equipment general description

The filter is composed of a metallic body, gear crown, main drain, opening valve (backwashing), a pump for injecting clean water to the nozzles and a geared motor for rotation crown and measure and control elements running. The filtering element is a special screen, fixed to the rotation crown, for filtering all kinds of dirt particles, with a hydrodynamic profile that provides low head loss and reduces turbulences, reduces head losses and avoid dirt particles accumulation.

All the materials are top-quality, in all the mechanic elements that are in contact with water it is used stainless steel or similar. The filter body is made of carbon steel. The mechanic elements are in the "clean water" side (water under the screen) in such a way that no foreign object can affect its performing or deterioration.

FMA-6000 filters fit directly to the pipe by means of flanges, as it was one more element of the pipe. Only the electric and control elements require installation.

It is a self backwashing automatic filter that has minimum maintenance and low consumption.

Performance

Water goes through the rotative screen and all the dirt particles bigger than the screen holes get filtered. When the default pressure differential, backwashing starts, this is made area by area, collecting waste materials to be expelled to the exterior.

The backwashing cycle starts when the default differential pressure is detected on both sides of the screen. At that moment, the crown starts spinning until an area is placed just in the backwashing chamber and then the backwashing valve is opened and the pump for water is started for water flooding through the nozzles, from the "clean water" screen side. A screen exhaustive backwashing is obtained by means of these nozzles. The backwashing valve stays open during the backwashing pre-set time and then it closes. The crown moves on to the following area and the opening and closing the backwashing valve and the water flooding pump cycle starts again.

When the sector is placed in the backwash chamber, this remains watertight due to the nylon bristles, for this reason, when the backwashing valve is opened, water flows through the filtration screen in the opposite sense than the filtration process which means an important saving in backwashing water consumption.

An electronic system protects mechanically the equipment. It is composed of an electronic torque limiter, a progressive starting system and a crown position electronic control.

In the case that any foreign object blocks the screen rotation, the system inverts the rotation alternatively until the foreign object is removed. In case it is too big, it will be extracted manually. An alarm signal will turn on if any system failure occurs.

Performance

FIRST STARTING UP:

The pipe has to be object-free. The filter rotation has to be initiated before there is water flow in the pipe.

COMMON PERFORMANCE:

When water flows through the filter, the dirt particles that are bigger than the filtration degree get retained on the screen. These particles produce an increase on the differential pressure. If this differential is not larger than 0.8 m.c.a, the filter backwashes according to the default time interval (8 hours, variable). If the the scale 0.8 m.c.a. is not exceeded, the differential pressure system detects the same one and the backwashing cycle starts.

Maintenance

The FMA-6000 filter has only a mobile piece and it is accesible from outside. The rest of the mobile pieces like engines and external valves are easily accesible. The rest of the maintenance is based on visual inspections and greasing.

The necessary spare pieces change according to the dust quantity, sand and number of backwashing cycles.

Screen technical characteristics

The "Double Diamond" screen is composed of quality AISI-316 electrowelded angle frames arranged 90° between the longitudinal and the transversal angle frames. The particles retention angle frames are rhombus-shaped so that water flow is possible (decrease head loss). This rhombus shape makes screen backwashing easier by means of reducing backwashing time.

Backwashing cycle

Backwashing time cycle is 90 seconds, from which, during 54 seconds the backwashing valve is open (including valve opening and closing time). For this reason, the backwashing consumption is quite reduced (if the factory worker does not manipulate the default times).

Remove the thick particles from the crown

In case the filtering crown is blocked with any thick element, this will get unblocked automatically. There is an electronic torque limiter in the system that detects when the crown is making more effort than the effort that there is on the design, then the screen changes its spin direction (backwashing just in the opposite direction).

If the crown gets blocked again, it will invert the spinning direction. If the blocking element could not become detached from the filter after several spinning direction changes, then a manual intervention would be carried out (opening the inlet and extracting manually the element that is stuck).

Head loss

Head loss for nominal flow is 0,4 m.c.a. (head loss is made with clean water).

TECHNICAL SPECIFICATIONS

Model	Connection inlet/ outlet		Drainage connection		Nominal flow m3/s			Installed power capacity
	DN	Inches	DN	Inches	Screen 1 x 1	Screen 1,5 x 1,5	Screen 2 x 2	
FMA - 6016	400	16"	80	3"	0.089	0.13	0.17	1.48 Kw
FMA - 6020	500	20"	100	4"	0.13	0.19	0.36	1.48 Kw
FMA - 6024	600	24"	125	5"	0.2	0.3	0.56	1.68 Kw
FMA - 6028	700	28"	150	6"	0.31	0.45	0.65	1.75 Kw
FMA - 6032	800	32"	150	6"	0.43	0.63	0.92	1.83 Kw
FMA - 6036	900	36"	200	8"	0.61	0.89	1.25	2.1 Kw
FMA - 6040	1000	40"	200	8"	0.78	1.14	1.53	2.57 Kw
FMA - 6044	1100	44"	200	8"	0.97	1.42	1.75	2.8 Kw
FMA - 6048	1200	48"	250	10"	1.16	1.69	2.22	3.35 Kw
FMA - 6052	1300	52"	250	10"	1.3	1.9	2.5	3.5 Kw
FMA - 6056	1400	56"	300	12"	1.61	2,35	3.33	3.7 Kw
FMA - 6060	1500	60"	300	12"	1.95	2.85	3.89	4.1 Kw
FMA - 6064	1600	64"	300	12"	2.33	3.4	4.17	4.3 Kw
FMA - 6068	1700	68"	350	14"	2.57	3.75	4.72	4.7 Kw
FMA - 6072	1800	72"	350	14"	2.83	4.14	5.14	5.2 Kw
FMA - 6076	1900	76"	400	16"	3.25	4.75	5.56	5.5 Kw
FMA - 6080	2000	80"	400	16"	3.7	5.41	6.67	6 Kw
FMA - 6088	2200	88"	450	18"	4.42	6.45	7,78	6.2 Kw
FMA - 6096	2400	96"	500	20"	5.14	7.5	8.89	6.38 Kw
FMA - 6104	2600	104"	500	20"	5.75	8.39	11.1	6.72 Kw
FMA - 6112	2800	112"	500	20"	6.54	9.55	13.06	7.1 Kw
FMA - 6120	3000	120"	600	24"	7.1	10.3	14.44	7.25 Kw

HEAD LOSS CHART

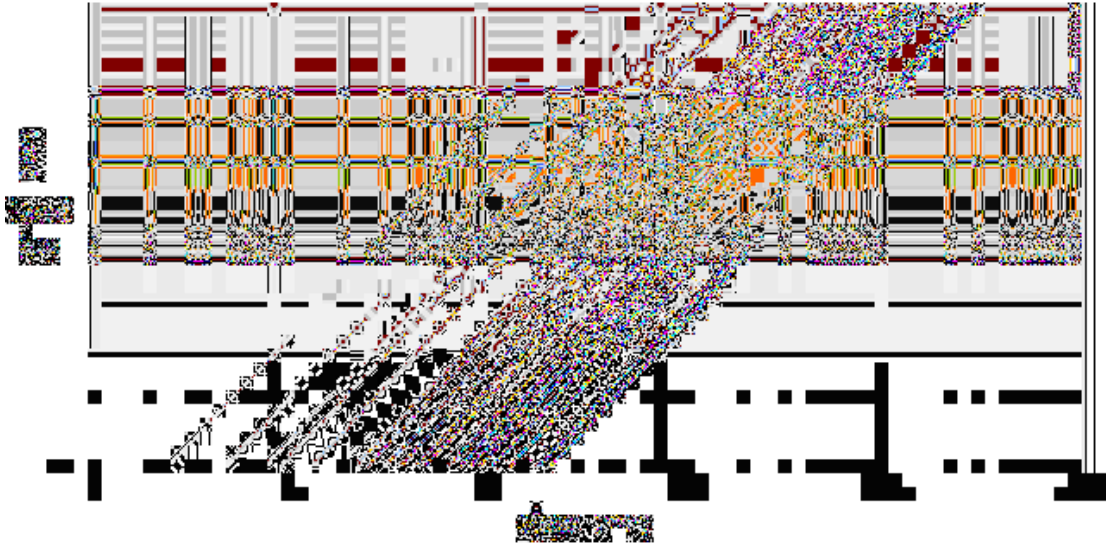

Screen 2 x 2 Double Diamond

FMA - 6016	FMA - 6020	FMA - 6024	FMA - 6028	FMA - 6032	FMA - 6036
FMA - 6040	FMA - 6044	FMA - 6048	FMA - 6052	FMA - 6056	FMA - 6060
FMA - 6064	FMA - 6068	FMA - 6072	FMA - 6076	FMA - 6080	FMA - 6088
FMA - 6096	FMA - 6104	FMA - 6112	FMA - 6120		

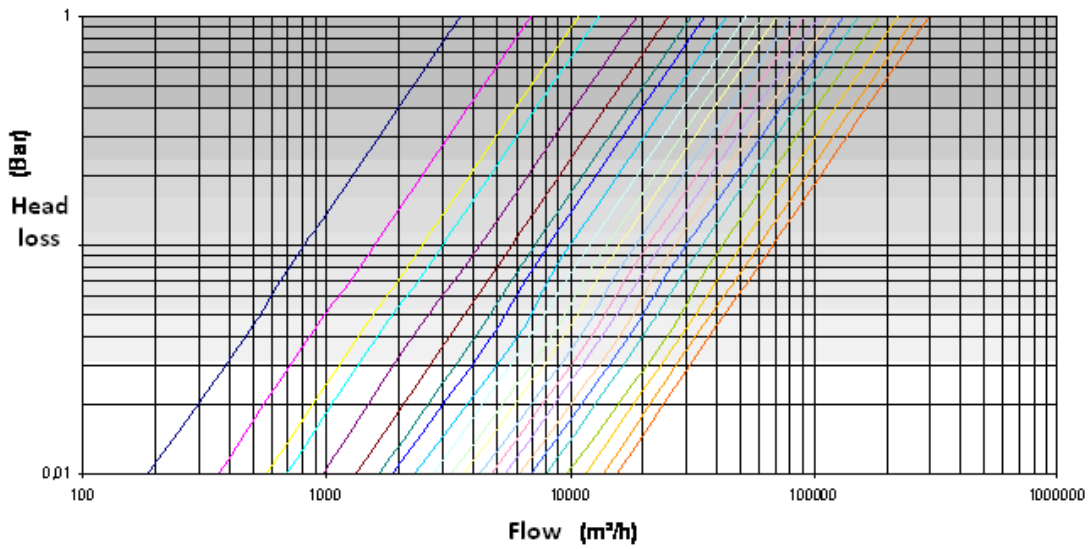

Screen 1,5 x 1,5 Double Diamond

SCREEN 1x1 DOUBLEDIAMOND

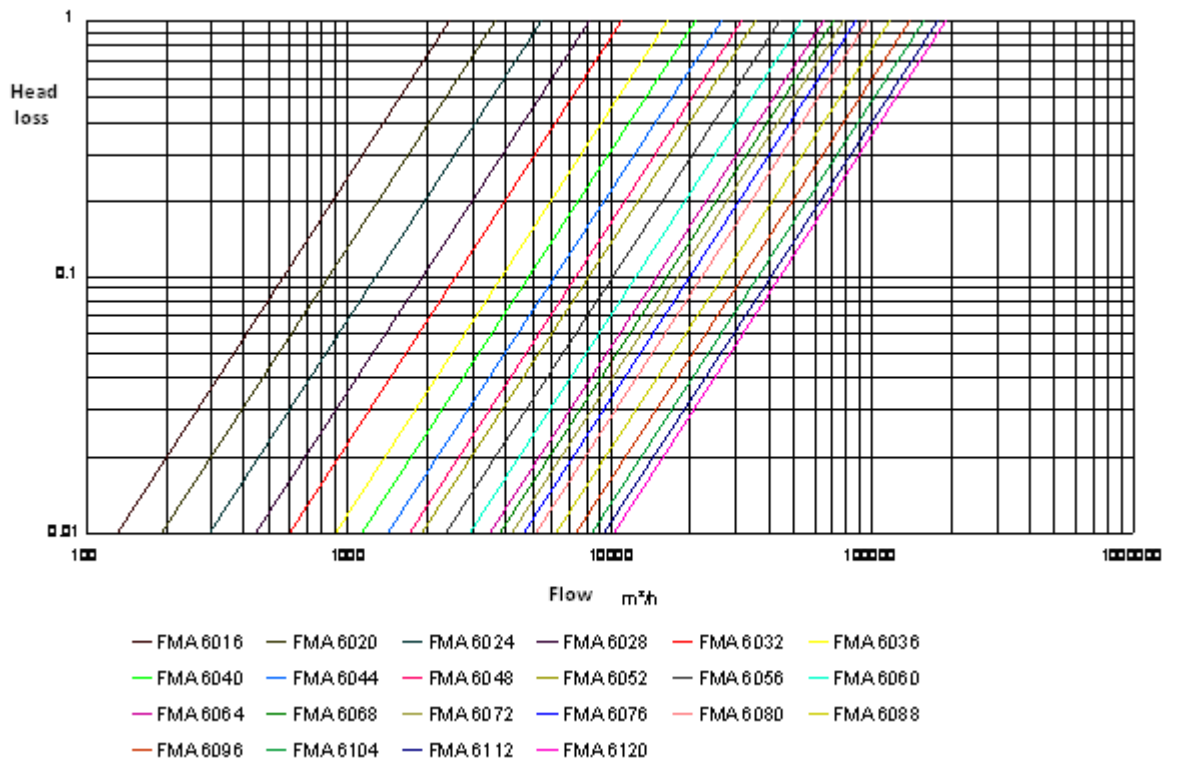

RECOMMENDED INSTALLATION DIMENSIONS AND DESIGN

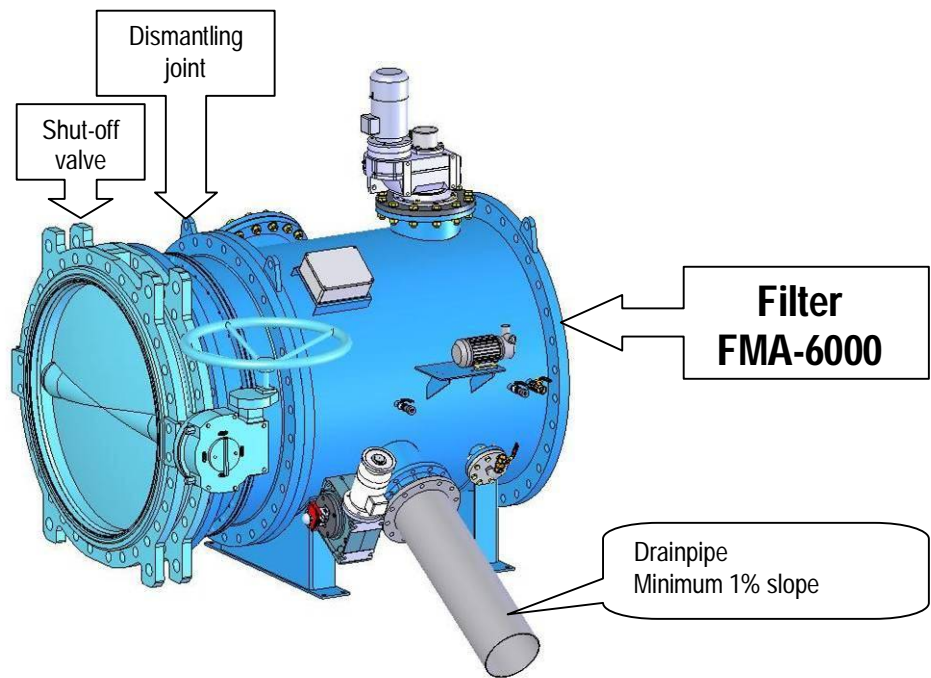

It is advisable to assemble a motorized butterfly valve together with a dismantling joint, previous to the filter. This is necessary in order to cut the water supply to the installation, in case of filter alarm or preventive maintenance.

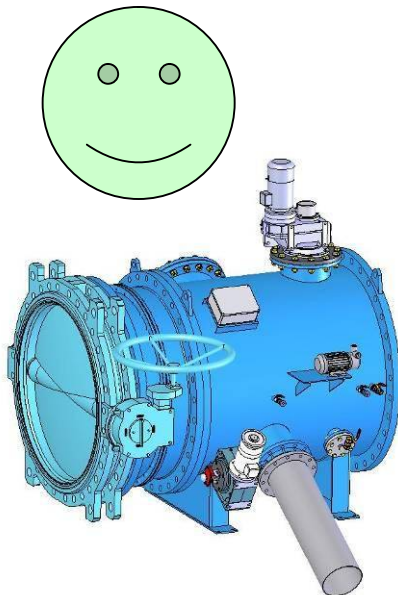

CORRECT
1% slope downwards

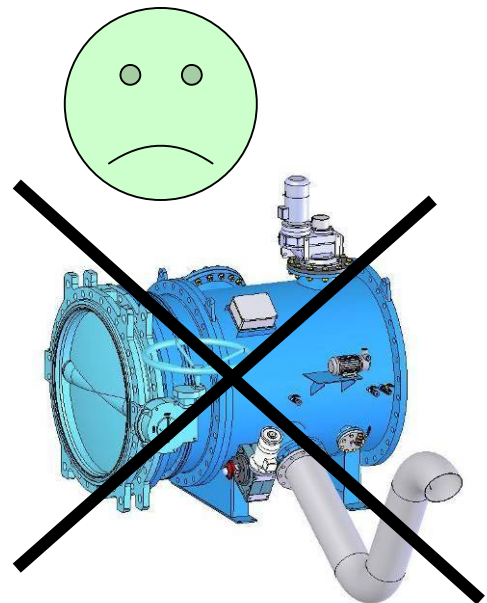

INCORRECT
The pipe gets blocked up with heavy solids.

START-UP AND FIRST OPERATION

1. Make sure that water flow direction coincides with the arrows indicated on the equipment.
2. A backflow valve has to be installed if it is foreseen reflux in the filter in order to protect the device from water hammer. ***STF is not responsible for any damages occurred on the equipment, in case of water hammers or pressures superior to the maximum design pressure.***
3. Butterfly valves have to be placed in the filter inlet and outlet to drain off the pipe and carry out the maintenance. (The outlet butterfly valve will depend on the equipment placement in the installation).
4. Disconnect the equipment.
5. Turn the circuit breakers to ON.
6. The equipment is already adjusted to operate correctly, (0.8 m.c.a pressure differential; 8 hours between safety backwashings).
7. The pipe has to be object-free. The filter rotation has to be started before there is water flow in the pipe.
8. Backwash manually when filling in the installation, until the pipe is pressurized completely.

INSTALLATION DIAGRAM

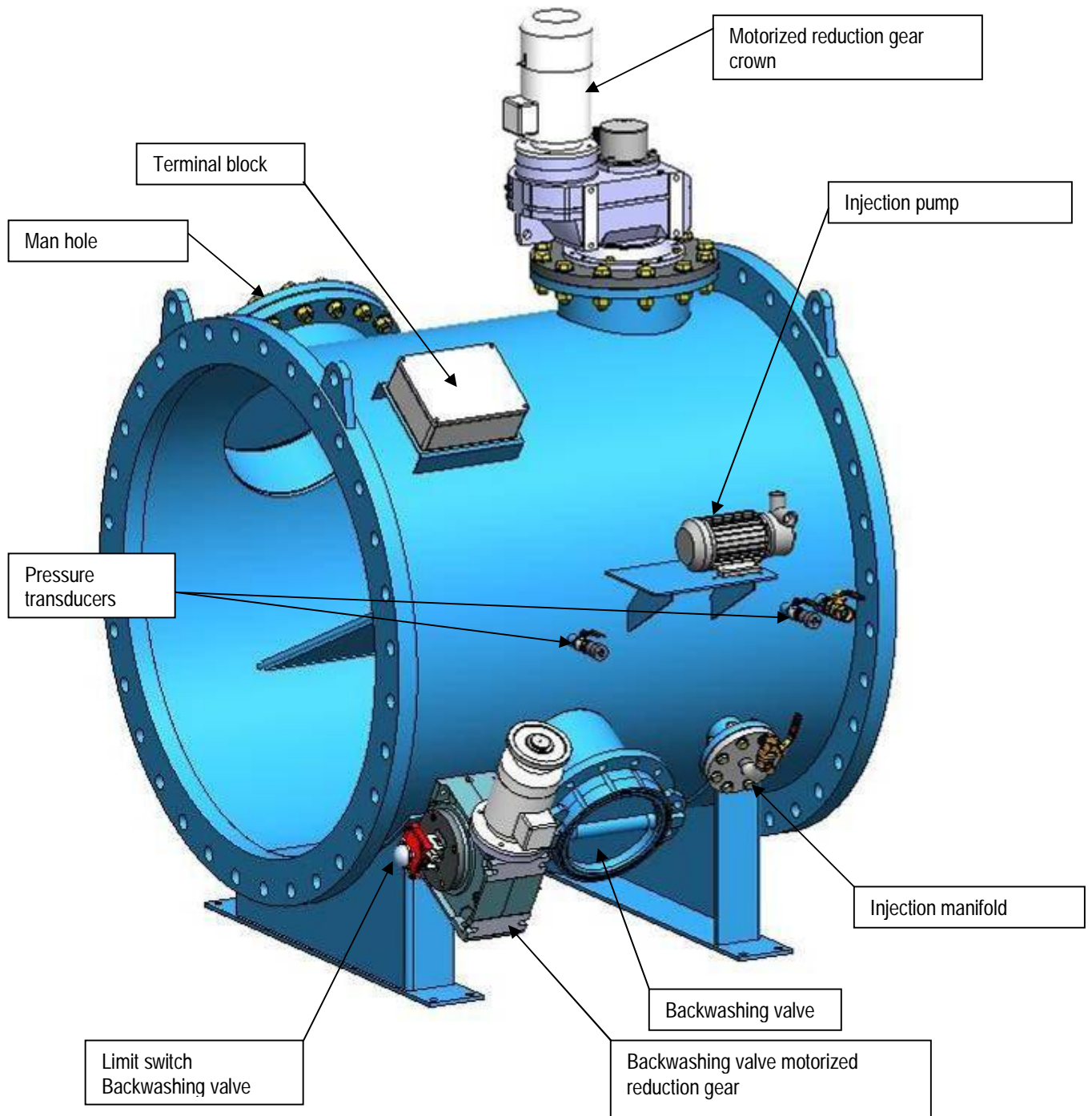

MASTER PANEL PERFORMANCE

The control panel of the self backwashing FMA-6000 is controlled from a touch screen that allows you to control and modify the equipment parameters.

STARTUP SCREEN (1)

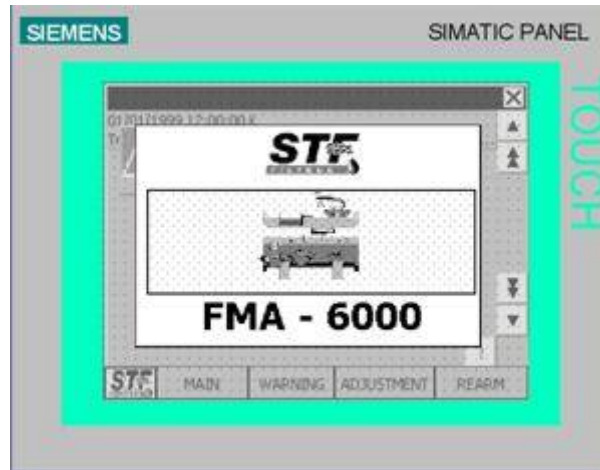

Touch the STARTUP SCREEN to have access to the MAIN MENU screen.

MAIN MENU SCREEN(2)

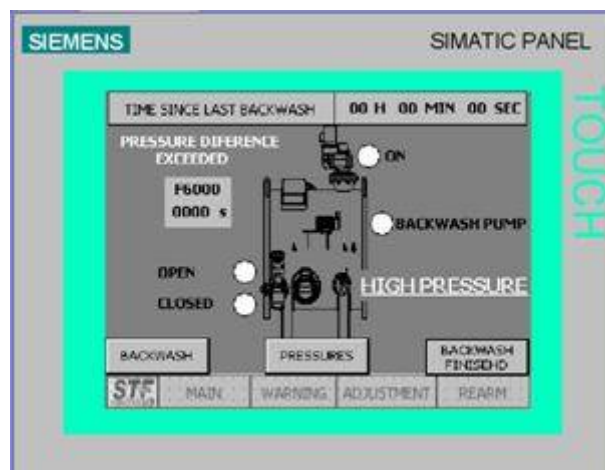

On the main menu screen, time since the last backwashing filter appears on the screen besides the backwashing time if its in the middle of the backwashing process.

The drain valve operation LEDS, the backwashing pump operation LEDS and the crown gear motor during the backwashing process appear in the filter diagram.

When the default pressure difference on the PRESSURE screen (4) is reached, the legend " EXCEEDED

PRESSURE DIFFERENCE" will appear on the screen. Besides this, in case of pressure excess, the legend "OVERPRESSURE" will be indicated.

If an alarm goes on or there is an operation failure, a triangle warning symbol will appear on the screen.

MENUS ACCESS:

- INSTALLATION BACKWASHING(3): This screen allows you to start the backwashing manually by pressing the STOP WASHING button, in this way the backwashing process is stopped, the drain valve closes, the backwashing pump stops and the crown rotation stops.

If you press X it returns to the previous screen (2).

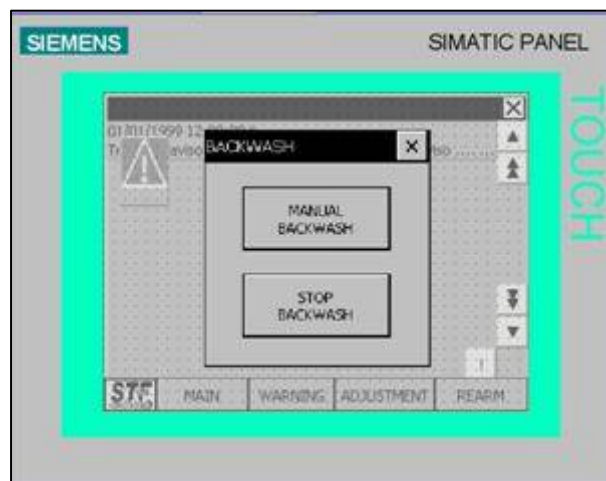

- BACKWASHINGS CARRIED OUT(4): This screen allows you to look up the backwashings number that have been carried out in the equipment according to the causes: If it has been manually (by means of the manual backwashing button), automatically (because of pressure differential) or because of time. Besides this, the total accumulated time is also indicated. Accumulated backwashings can not be deleted and also the number of total backwashings that the equipment carries out between the STF maintenance processes is indicated. Only STF personnel can turn this value to zero.

If you press X it returns to the previous screen (2).

If you press BACKWASHINGS RESET the updating screen will appear.

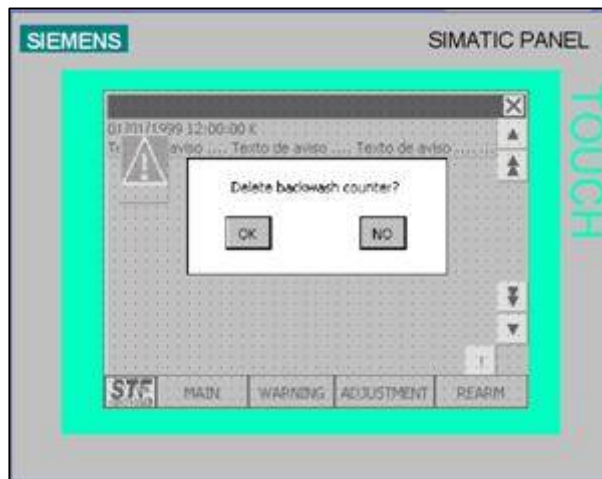
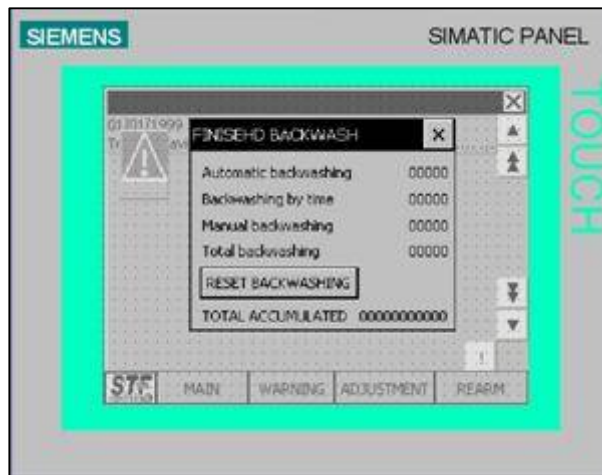

- PRESSURES (5): This screen allows you to look up both the inlet and the outlet pressure. Besides the real time pressure differential in water column pressure. In the last variable "set point pressure difference" it allows us to select to what pressure differential we want to start a backwashing. The alarm value for overpressure is the value at which the overpressure alarm will be indicated.

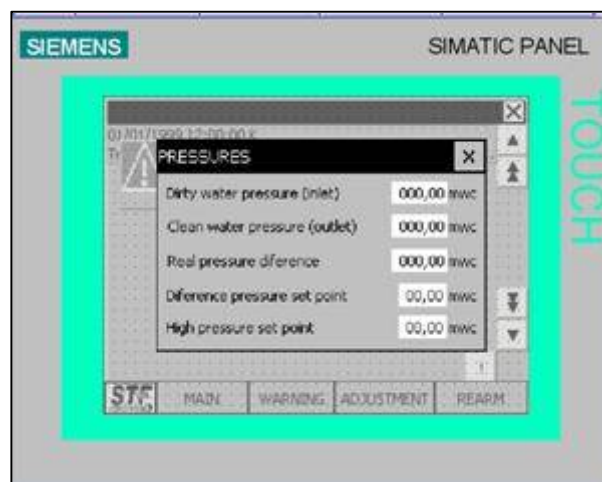

The menu, which is common to all the screens, appears at the bottom of the screen. In this menu it is possible to have access to:

WARNINGS screen (7)

ADJUSTMENTS screen (10)

REARM screen (11)

WARNINGS (7)

In the warnings menu, we can select the option to check the current alarms, to see the warnings record since the the last updating and to delete the alarm record.

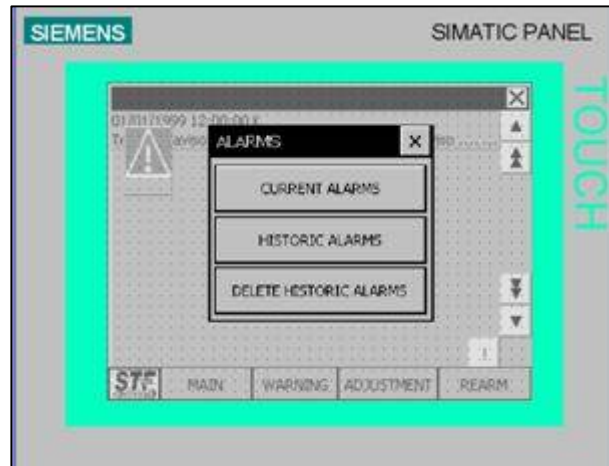

If you press X it returns to the previous screen .

The ALARMS screen indicates the actual warnings that are still to be corrected in the installation, indicating the warning reason and the moment when they occurred.

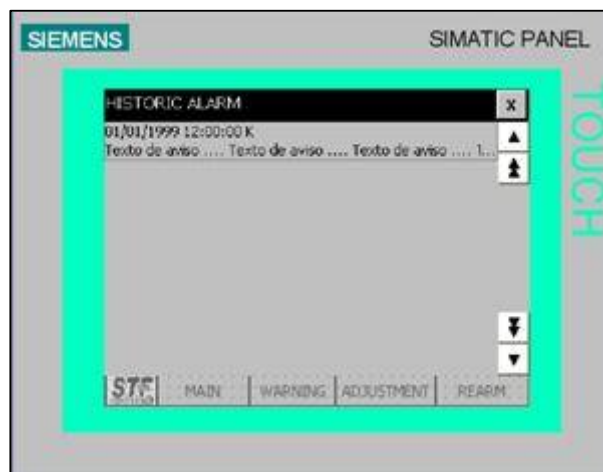

The list is updated to check if the error has been corrected with the right inferior key. The blue triangle will appear on the menu screen if there is an active warning.

The alarms record screen indicates all the warnings that have appeared since the last deletion. If we push DELETE THE ALARMS RECORD the option to delete all the no active warnings will appear.

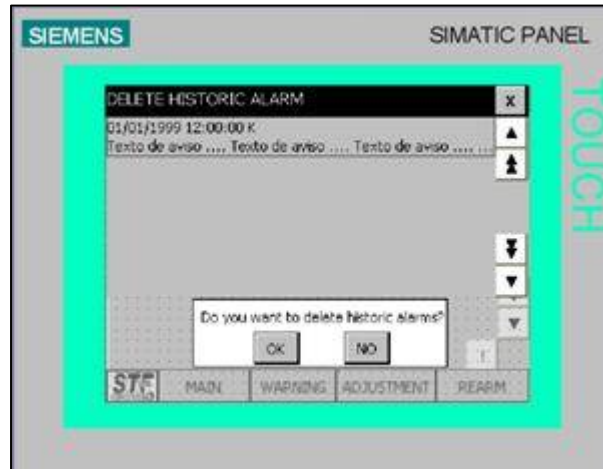

When the programmer makes the consecutive backwashings indicated in the parameter "CONSECUTIVE BACKWASHINGS ALARM" with no continuity, the safety device that stops the backwashing will activate. The text (2) "ALARM" will appear on the screen in the inferior right hand side and on the alarm screen. The legend: CONSECUTIVE BACKWASHINGS ALARM will appear.

This alarm indicates that the pressure switch sends a continuous signal to the electric panel, this can be due to a pressure switch failure, to the fact that it has got blocked or to dust excess.

Unblock the pressure switch and press the REARM button to cancel the alarm.

ADJUSTMENTS(10)

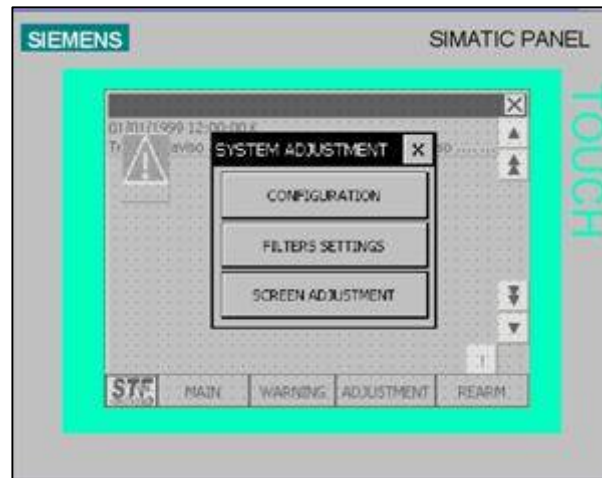

screen (10) allows you to configure the installation parameters, the filter operating times and to adjust the touch screen.

CONFIGURATION (11):

The CONFIGURATION screen allows you to adjust the backwashing process modifying several parameters such as delay time, pressure difference to start backwashing, opening and closing the backwashing collector butterfly as well as the continuous backwashing time.

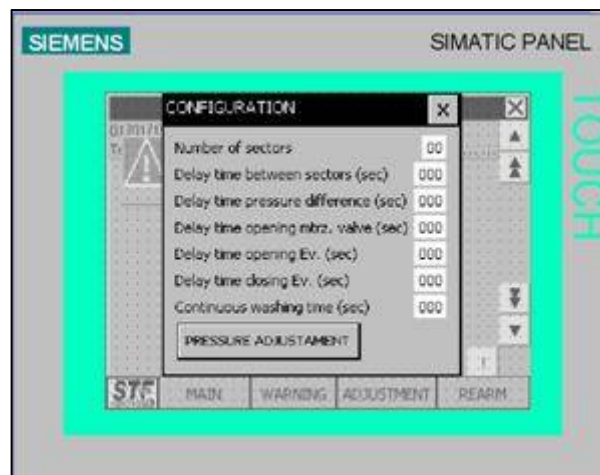

Pressing the "PRESSURE ADJUSTMENTS" touch button it is possible to have access to the pressure adjustments screen where the pressure parameters are modified.

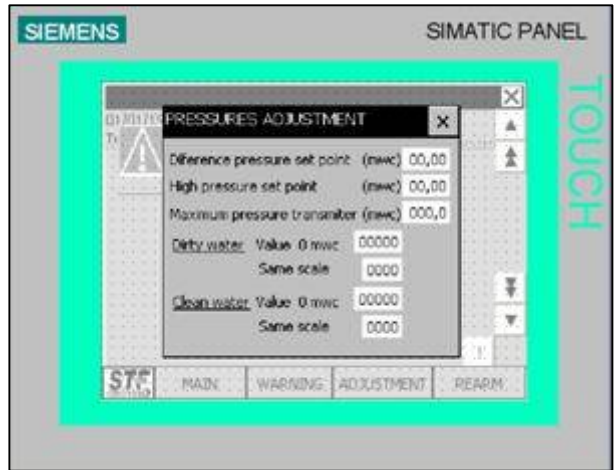

PARAMETERS (12):

The PARAMETERS screen allows you to modify the default values to control the backwashing process and activate the alarms in case there is any failure. On this screen it is possible to modify the number of consecutive backwashings, the number of consecutive blockages, the backwashing time and the time between backwashings in case that the backwashing is not due to pressure difference.

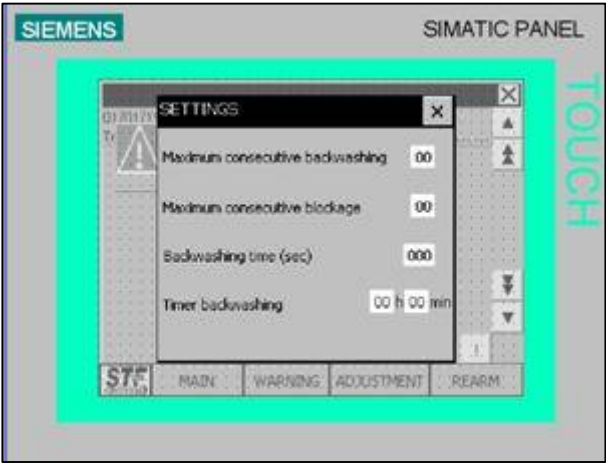

SCREEN ADJUSTMENTS (13):

The ADJUSTMENTS SCREEN allows you to have access to the previously mentioned screens (backwashings carried out (5)), as well as to set the screen sensibility (14) or to set date and time (15).

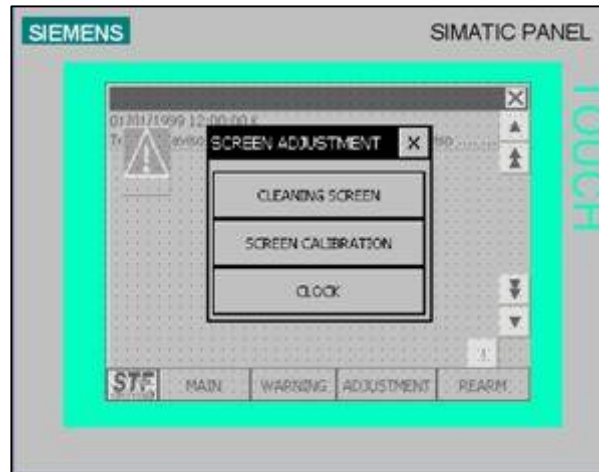

TOUCH SETTING (14): It is possible to adjust the pressure values to make a filtering process more effective on the touch setting screen.

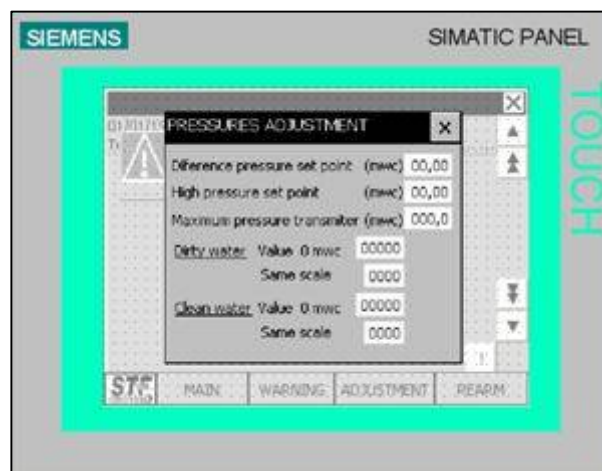

WATCH (15):

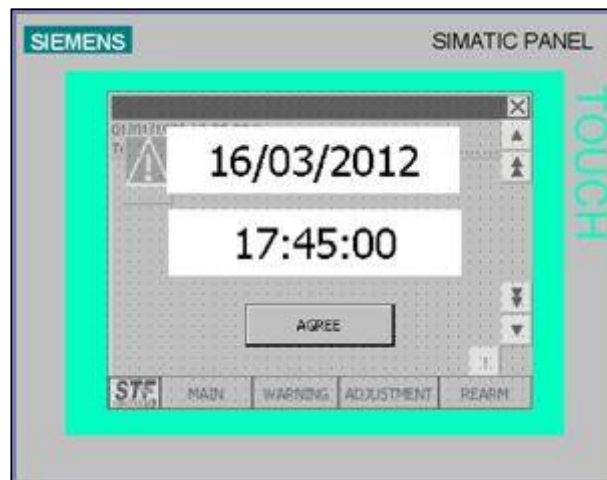

IMPORTANT:

WHEN THE FILTER TRIGGERS THE ALARM SIGNAL, THIS MUST BE CARRIED OUT IMMEDIATELY TO STOP WATER FLOODING THROUGH THE FILTER BY CLOSING THE BUTTERFLY VALVE BEFORE THE FILTER.

PRESSURE DIFFERENTIAL REGULATION

The pressure differential regulation is made in an electronic way by means of pressure transducers 4 - 20mA located in the inlet and the outlet. These transducers give a stable and precise signal of pressure in both filter chambers and the electric panel calculates the pressure differential.

The pressure differential is regulated to 0.8 m.c.a and it can only be changed by STF-Filtros technical skilled personnel.

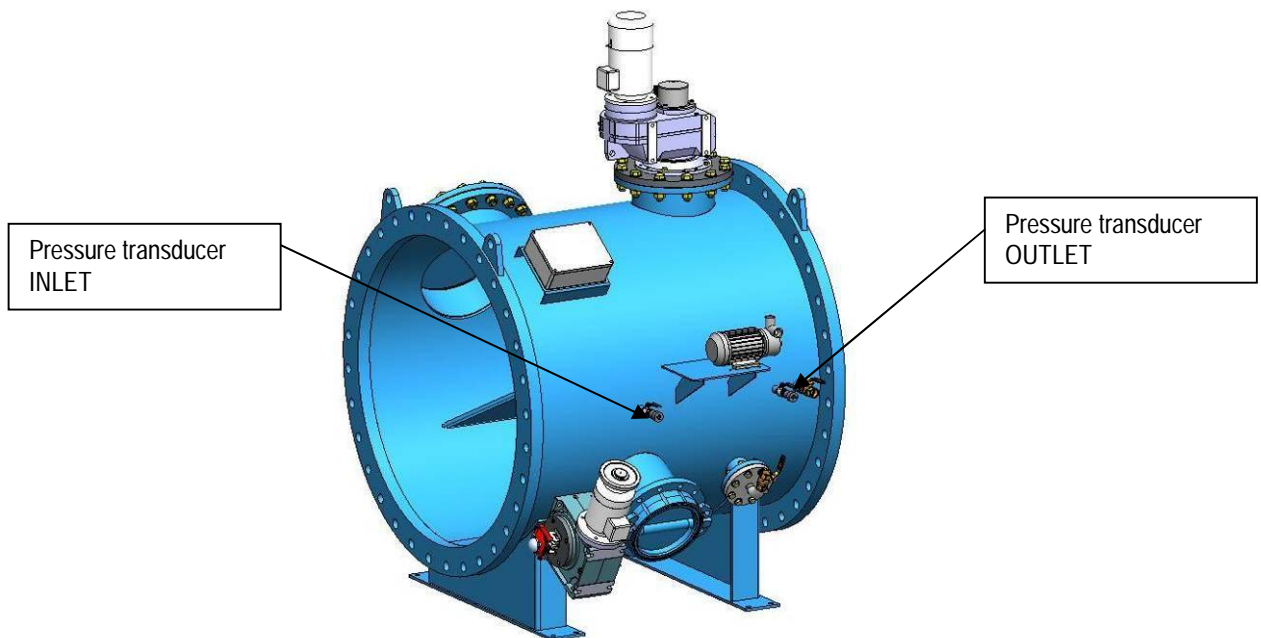

EXPLOSION DIAGRAM

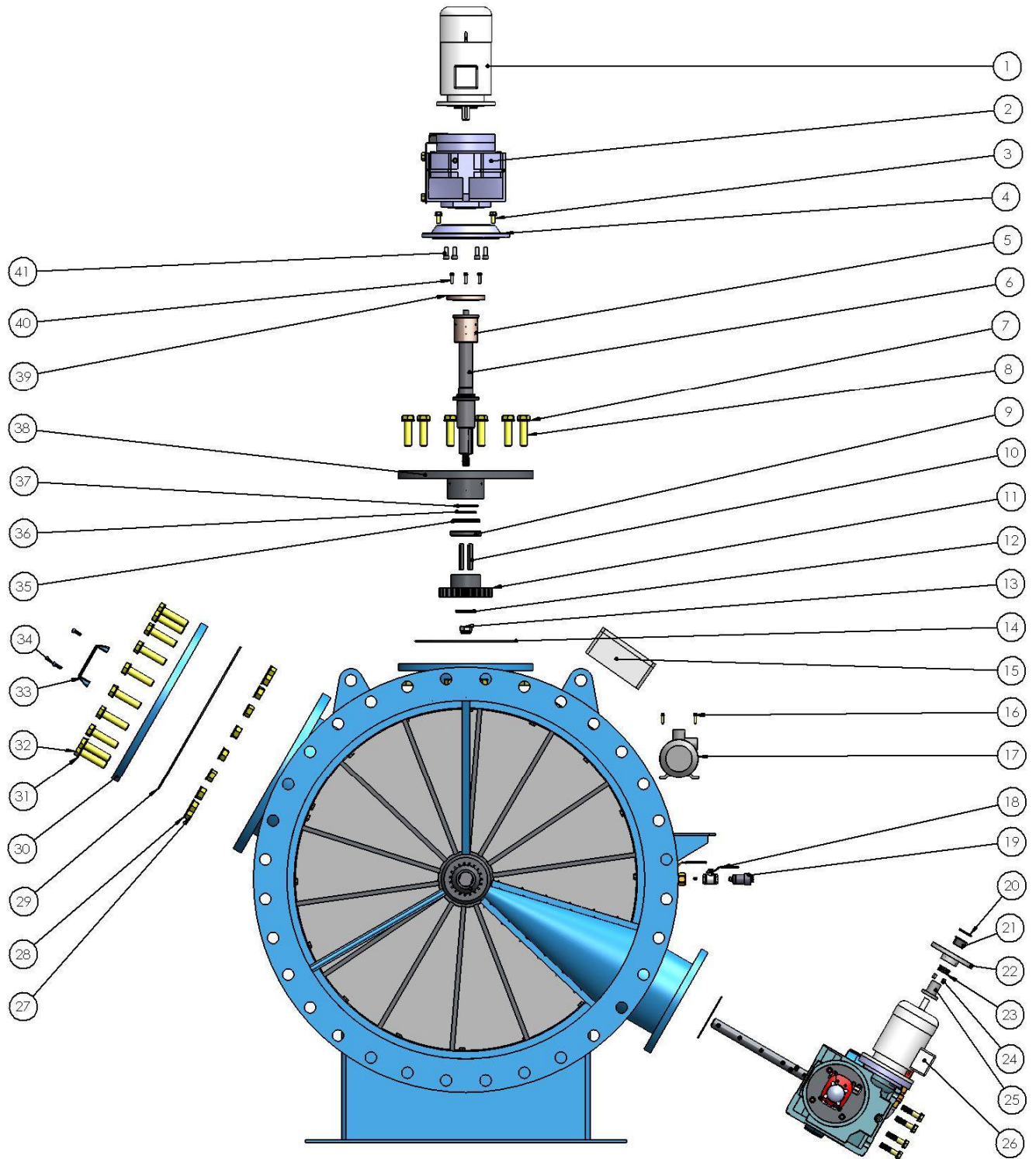

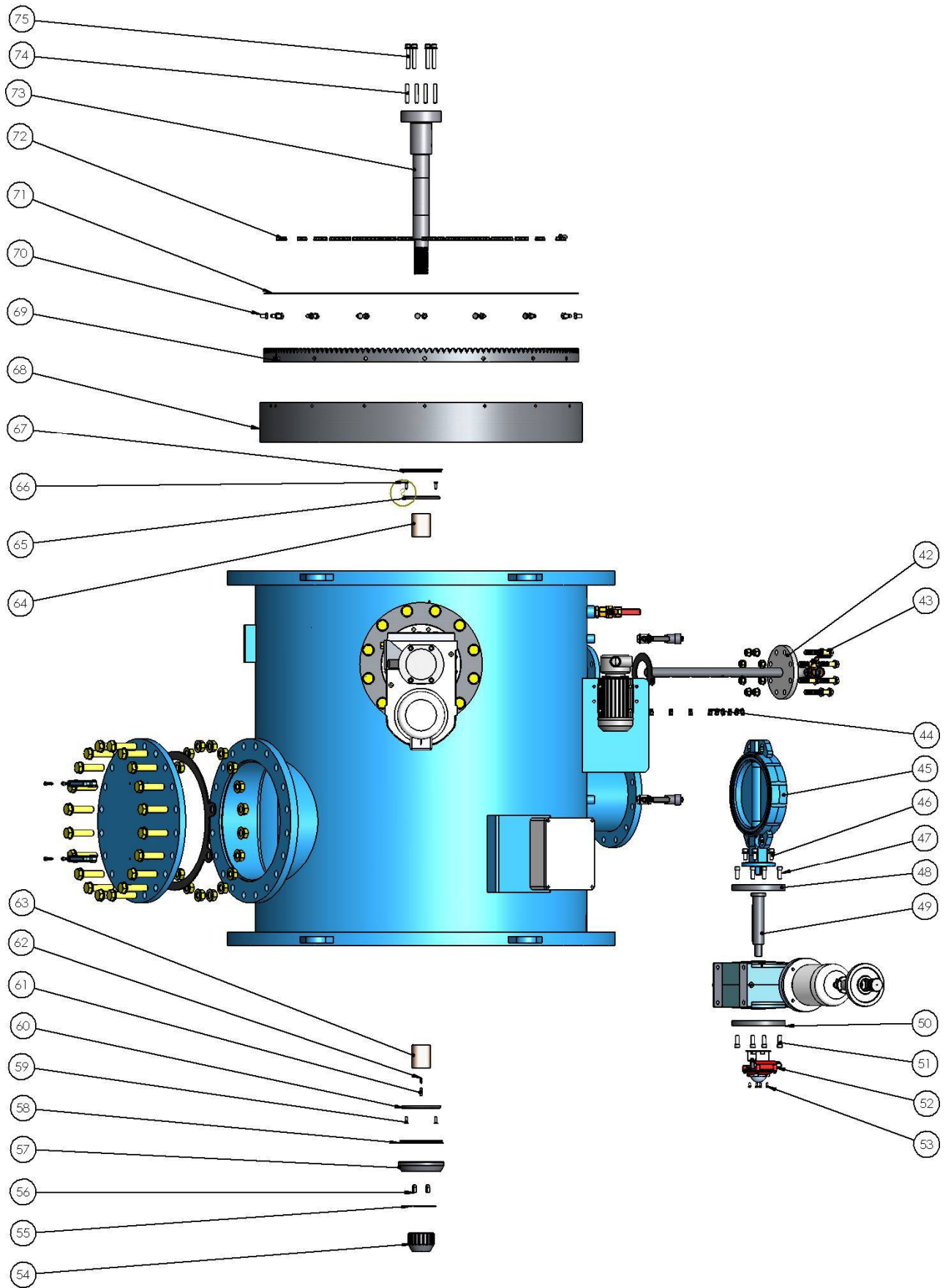

POSITION	DESCRIPTION	CODE
1	Crown motor	
2	Crown reducer	
3	Outlet flange scew	
4	Outlet flange	
5	Crown gear motor guide bush	
6	Drive shaft	
7	Washer	
8	Screw	
9	Rectified washer	
10	Pinion machine key	
11	Pinion	
12	Pinion washer	
13	Pinion nut	
14	O-ring joint	
15	Electrical Junction Box	
16	Pump screw	
17	Injection pump	
18	Needle valve	
19	Pressure transducer	
20	Clutch washer	
21	Clutch bush	
22	Clutch wheel	
23	Clutch spring	
24	Clutch cylindrical dowel pin	
25	Gear motor clutch connection	
26	Backwashing valve gear motor	
27	Man hole nut	
28	Man hole washer	
29	Man hole flat joint	
30	Man hole blind flange	
31	Man hole washer	
32	Man hole screw	
33	Handle	
34	Handle screw	
35	Crown gear motor VA joint	
36	Crown gear motor quadric joint	
37	Crown gear motor o-ring	
38	Crown gear motor flange	
39	Flap	

POSITION	DESCRIPTION	CODE
40	Crown gear motor flap screw	
41	Gear motor outlet flange screw	
42	Nozzles distribution manifold	
43	Nozzles manifold screw	
44	Nozzles	
45	Backwashing valve	
46	Connection flange screw	
47	Gear motor connection flange screw	
48	Connection flange	
49	Butterfly valve drive shaft	
50	Butterfly valve limit switch flange	
51	Limit switch flange screw	
52	Limit switch	
53	Limit switch screw	
54	Crown main nut	
55	Crown shaft primary washer	
56	Crown shaft machine key	
57	Crown shaft secondary washer	
58	Crown shaft VA joint	
59	Axial busher screw	
60	Axial washer	
61	Screw	
62	Spring screw	
63	Crown shaft guide bush	
64	Crown shaft guide bush	
65	Axial washer	
66	Axial washer screw	
67	Crown shaft VA joint	
68	Crown	
69	Gearwheel	
70	Gearwheel screw	
71	Filtering screen	
72	Filtration screen screw	
73	Crown main shaft	
74	Main shaft dowel pins	
75	Crown shaft screw	

Materials

THE FILTER BODY

Body	Carbon steel	S-235-JR
Suction ajutage	Stainless steel	AISI-304
Structural rings	Stainless steel	AISI-304
Flanges support	Stainless steel	AISI-304
Internal protection	Epoxi alimentario	
External paint	Epoxi-polyester	

FILTERING CROWN

Structure	Stainless steel	AISI-304
Screen panels	Stainless steel	AISI-304
Shaft	Stainless steel	AISI-304
Hub bearing	Stainless steel	AISI-304
Machinery	Stainless steel	AISI-304
Supports	Stainless steel	AISI-304

TRACTION MECHANISM

Frame	Stainless steel	AISI-304
Driving shaft	Stainless steel	AISI-304
Bearing	Aluminium bronze	
Pinion	Stainless steel	AISI-304

BACKWASHING VALVE

Body	Epoxi ductile iron	
Disk	Epoxi ductile iron	
Coating	EPDM	
Shaft	Stainless steel	AISI-304

HYDRAULIC LAYOUT

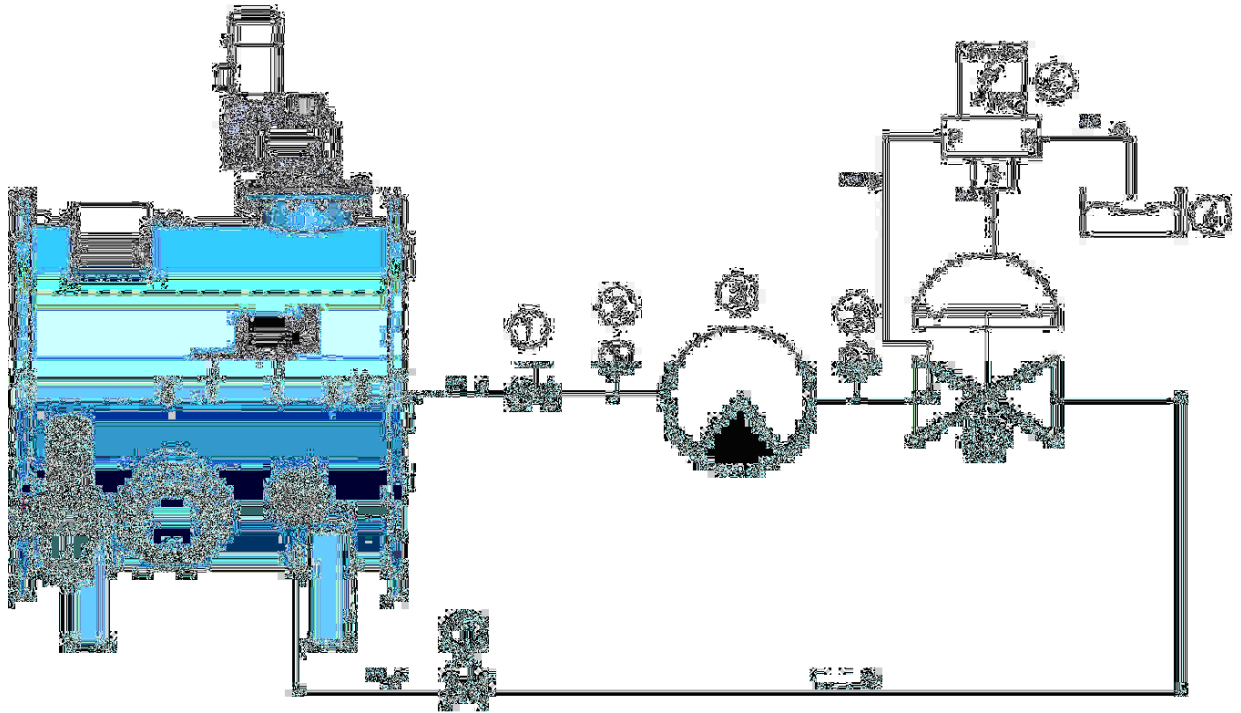

- 1- Ball valve
- 2- Pressure gauge
- 3- Pressurization pump
- 4- Hydraulic valve
- 5- Solenoid
- 6- Drainage

ELECTRIC PANEL

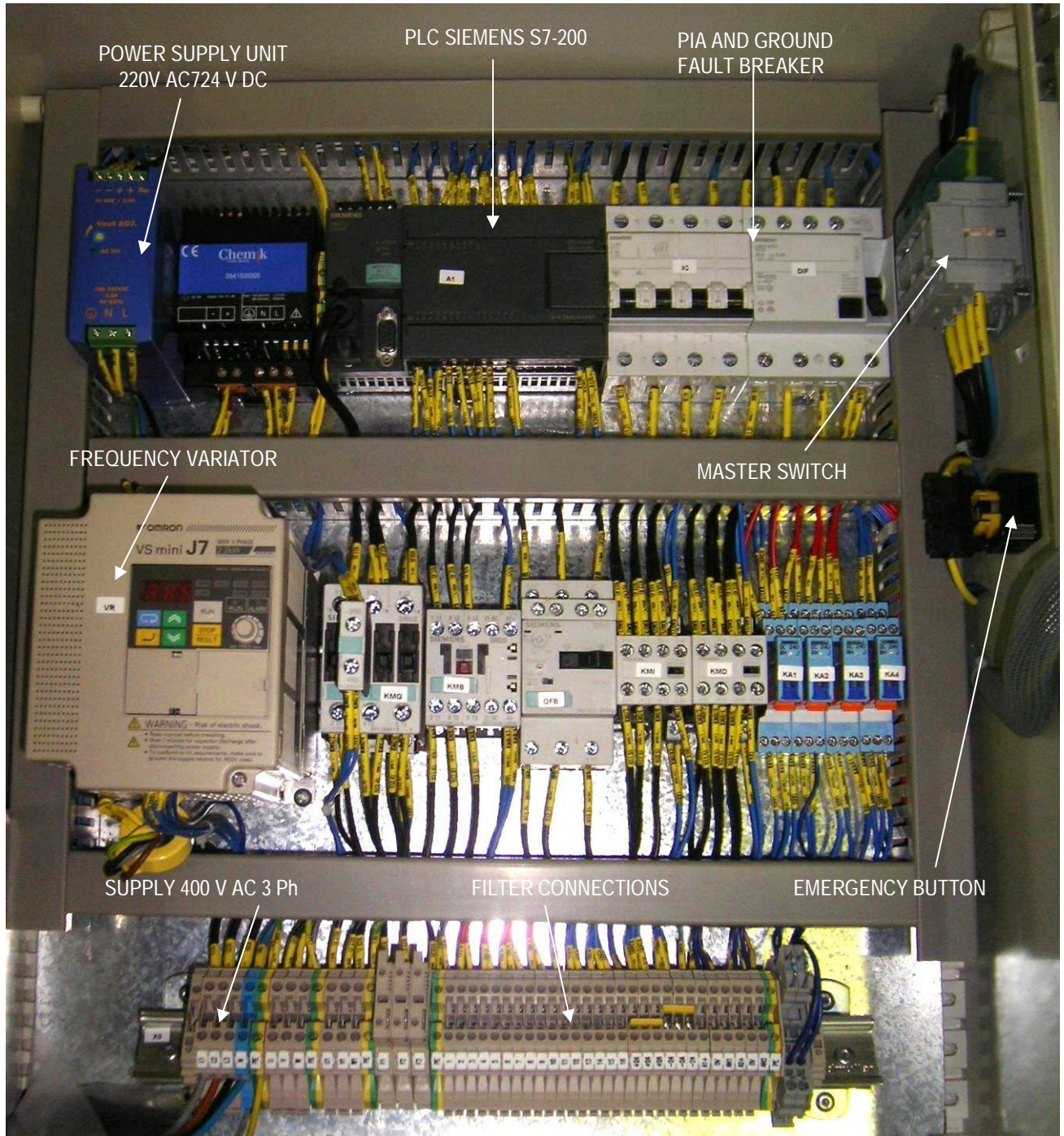

ELECTRIC LAYOUT

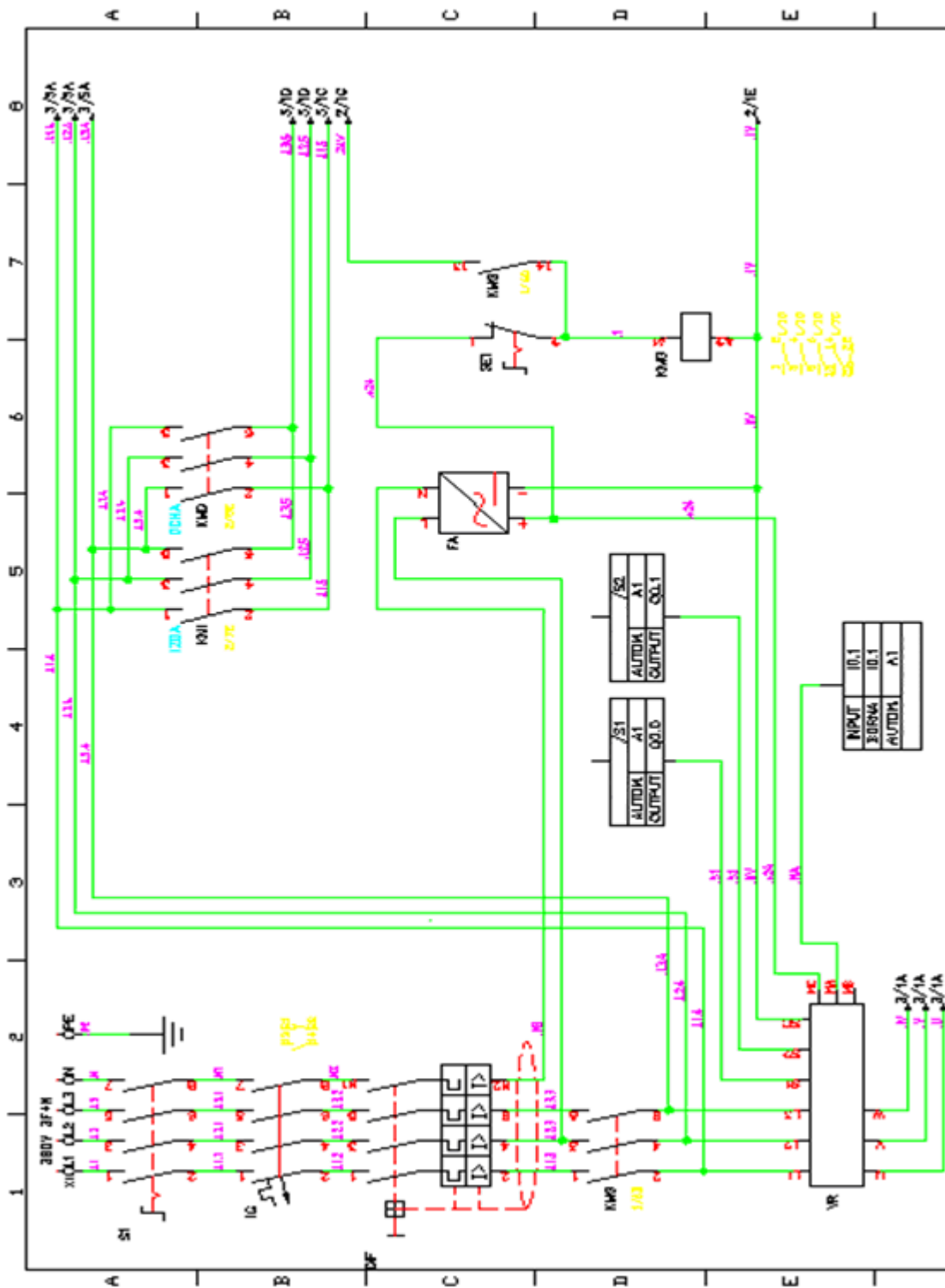

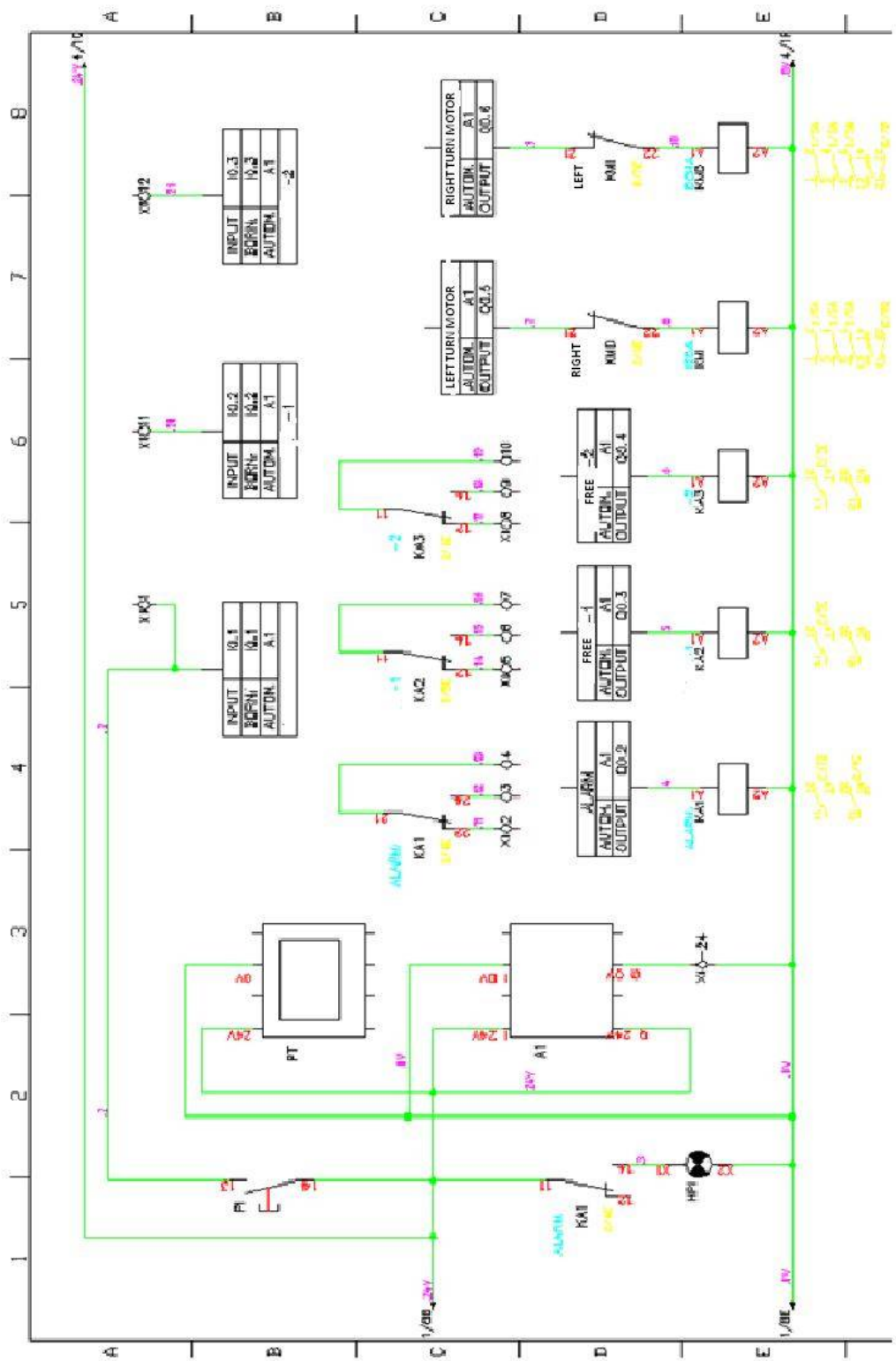

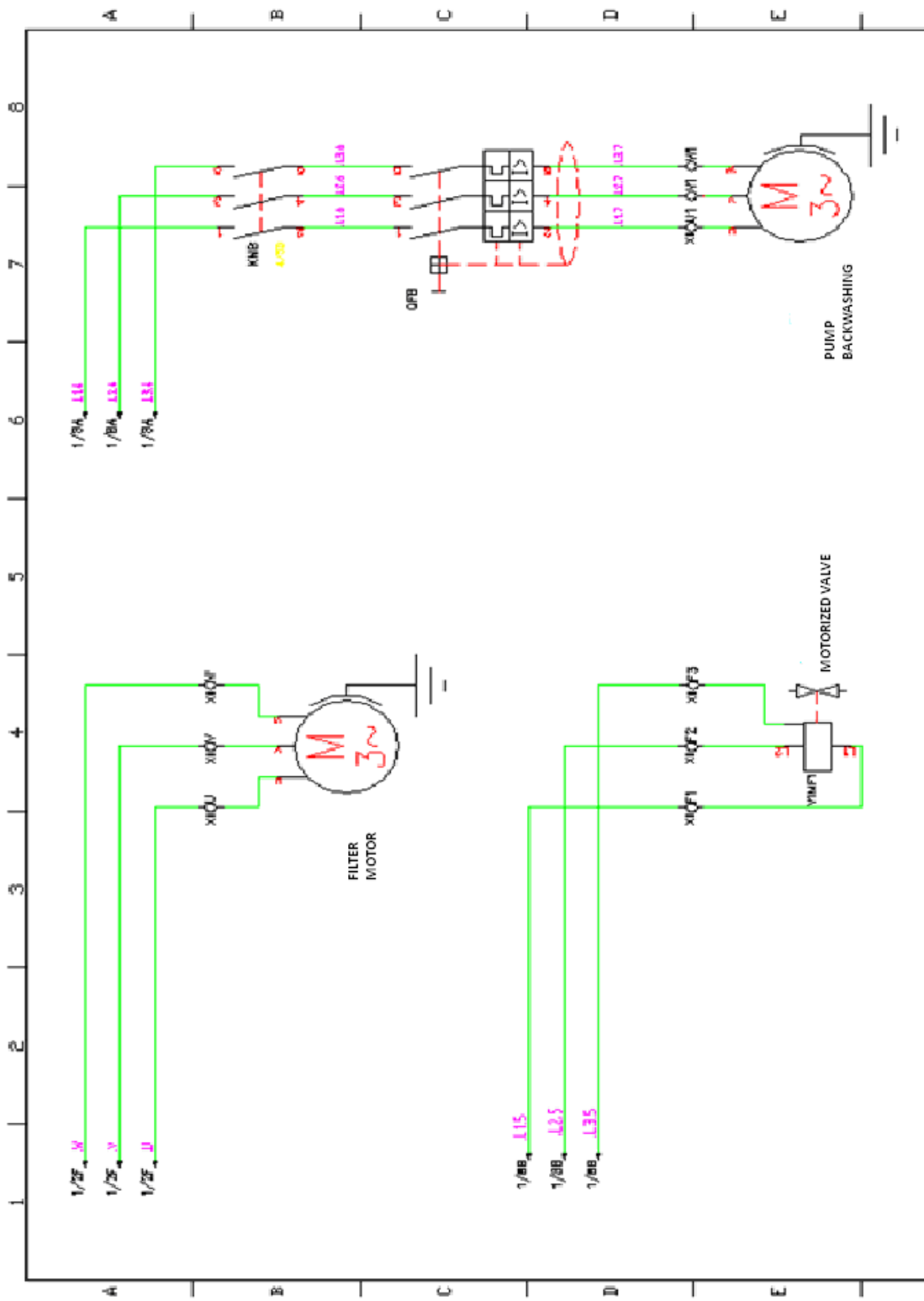

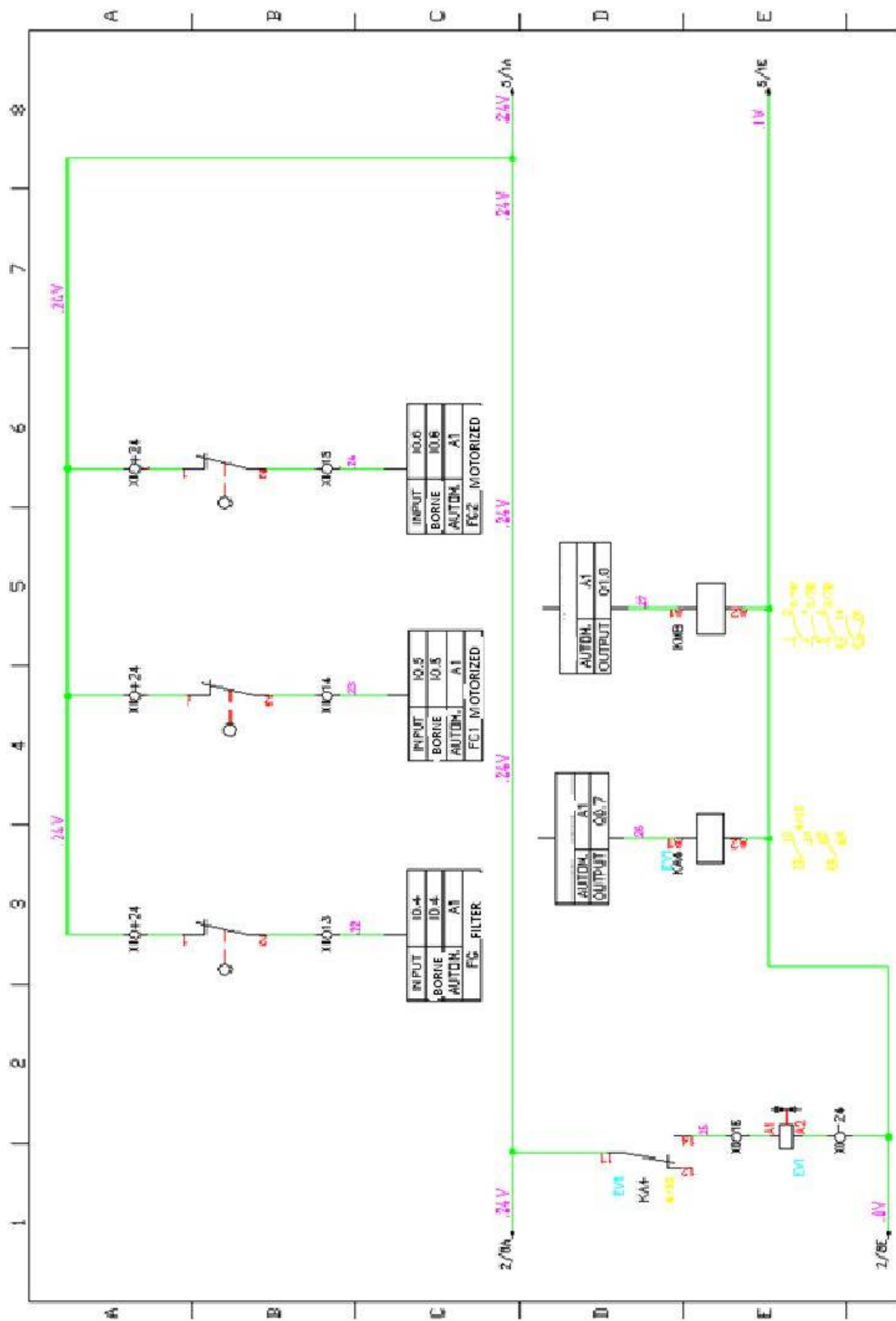

PREVENTIVE MAINTENANCE SCHEDULE

Grease the indicated pieces every **3 months**.

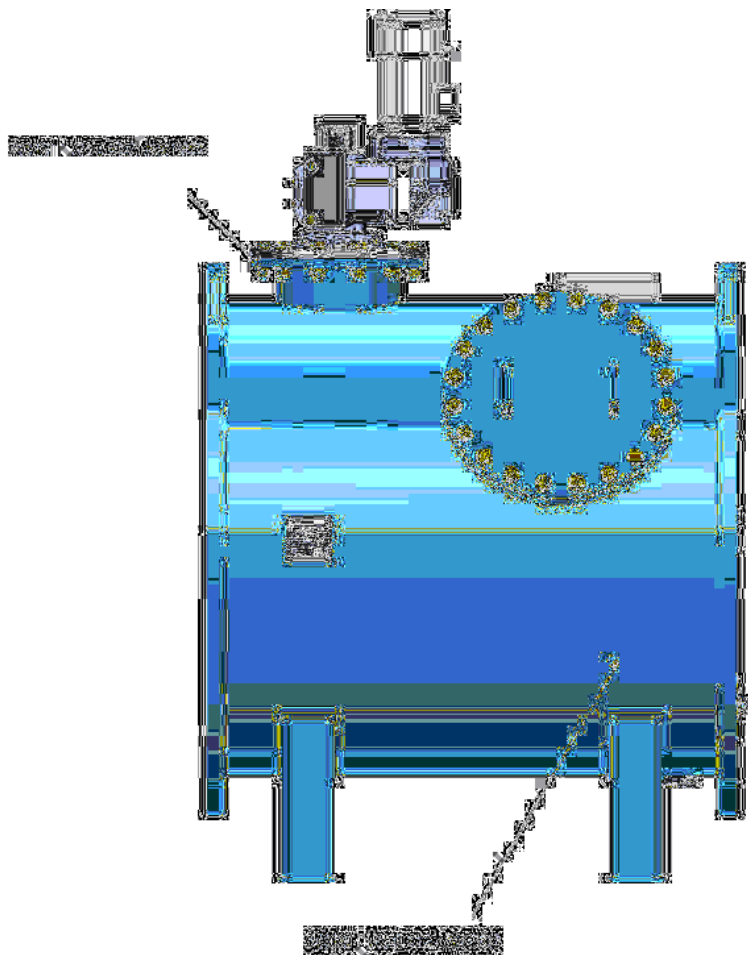

If a long stop is planned, backwash once a week so that all the mechanisms get lubricated.

It is not necessary to make any other maintenance, gearmotors have enough oil for its useful life.

FMA-6000 filter has a mobile piece and it is accessible from outside. The rest of the mobile pieces such as engines and valves are external and easily accessible. The rest of the maintenance is based on visual inspections and greasing.

REFERENCES



